

Air handling unit with 4 row cooling coil from 4.5 up to 32 kW  
 5.5 a 40 kW 6 row coil  
 heating efficiency with 4 row coil from 14.0 up to 78.0 kW  
 15.5 a 87.5 kW 6 row coil



- **HORIZONTAL OR VERTICAL CONFIGURATION**
- **VERSION WITH 4–6 ROWS WATER COIL**
- **VERSION WITH 4 ROW EXPANSION COIL USING R410A**
- **VERSION WITH EXTRACTOR**

## Features

The air conditioning units in the TA range are destined to civil, commercial and hotel systems, for applications in small to medium sized environments.

The units in the TA range are characterised for their compactness (indispensable requisite for typical suspended-ceiling applications), the low noise and high useful static pressure.

The great availability of accessories (e.g. bag filters and the mixing chambers with 3 dampers) allows to satisfy the most varied plant requirements

- **Structure** realised with sandwich panels with thickness of 15 mm with polyurethane (density 40 kg/m<sup>3</sup>). The intake panel is equipped with a flange for fitting to any air channels.

Horizontal or vertical fixing to a wall is made easy by the brackets.

- **Filtration** of the air entrusted to class G4 filters in compliance with EN779 (thickness 50mm) as per standard positioned at intake.
- **Fans** double intake centrifugal with forward blades and directly coupled motor. The 230V-50Hz single-phase motor has many speeds, of which three can be selected via the control panel.
- **Condensate drip tray** interior isolated in aluminium alloy.
- **Coils with 4, 6 rows** that can be fed with hot or cooled water realised in coil in copper piping with aluminium louvers blocked via mechanical expansion of the pipes. Threaded

sleeves are supplied for the hydraulic attachments and the air vent valve.

The possibility to rotate the coils on site is envisioned.

- Also available are coils with 4 rows with direct expansion operating with R410A fluid and post-heating coils with 1 and 2 rows realised in copper piping with aluminium louvers blocked via mechanical expansion of the pipes.

## Choosing the unit

By appropriately combining the variety of options available, it is possible to configure every model in a manner that satisfies all specific implant requirements.

### Fields configurator:

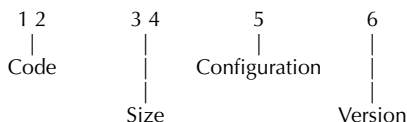

#### Code:

TA

#### Size:

09, 11, 15, 19, 24, 33, 40, 50

#### Configuration:

H - Horizontal

V - Vertical

X - Extractor

#### Version:

4 - Coil with 4 rows

6 - Coil with 6 rows

E - R410A coil with direct expansion 4 left rows

Example of a sale code: **TA09H4**

This is a TA unit, size 09 horizontal with 4 row coil.

## Accessories

- M2S 2 damper mixing chamber**  
 Galvanised sheet steel section complete with two air calibration dampers with galvanised sheet steel louvers.  
 Louver pitch 50 mm; regulation pin in galvanised steel with diameter 8 mm mechanisation.
- M3S 3 damper mixing chamber**  
 Galvanised sheet steel section complete with three air calibration dampers and galvanised sheet steel louvers.  
 Louver pitch 50 mm; regulation pins in galvanised steel with diameter 8 mm mechanisation.  
 Va must be coupled with the VRF accessory
- FTF Soft bag filters section**  
 Galvanised sheet steel section complete with soft bag filters with F6 filtration level.  
 For different filtrations, contact the AERMEC technical-sales dept.
- B1R 1 row water coil**  
 For 4 pipe systems, positioned internally, downstream from the main coil.  
 Threaded sleeves are supplied for the hydraulic attachments and the air vent valve.
- B2R 2 row water coil**  
 For 4 pipe systems, positioned internally, downstream from the main coil.  
 Threaded sleeves are supplied for the hydraulic attachments and the air vent valve.
- PBE Section with post-heating coil**  
 The electric coil is made up from armoured resistances equipped with double safety thermostat.
- SSL Module with seven silencers**  
 Galvanised sheet steel section complete with seven silencers in mineral wool covered with a polyethylene film to prevent exfoliation.
- S2Z Damper with 2 areas (70-30%)**  
 Galvanised sheet steel damper with opposite louvers for the mixture of the external air flow and the flow of recirculation air.
- Louver pitch 50 mm; regulation pin in galvanised steel with diameter 8 mm mechanisation.
- VRF Recovery fan section with G4 filter**  
 Fan unit, equipped with electronic varistor of the number of revs. contained in a section in galvanised sheet steel equipped with flat filters with G4 efficiency (EN779).
- PMM Plenum with multiple circular flows**  
 Plenum equipped with sandwich panelling with thickness of 15 mm in galvanised steel with polyurethane insulation. The plenum is supplied with multi-diameter circular attachments (200 mm, 180 mm and 150 mm) in plastic to allow the connection of circular conduits.
- PMC Closed flow plenum**  
 Plenum closed equipped with sandwich panelling with thickness of 15 mm in galvanised steel with polyurethane insulation.  
 The plenum allows to turn the flow by 90°. The opening of the flow hole is the installer's responsibility.
- SAS Intake damper**  
 Air calibration damper with galvanised sheet steel louvers.  
 Louver pitch 50 mm; regulation pin in galvanised steel with diameter 8 mm mechanisation.
- GMD Flow grid with moveable louvers**  
 Grid with double order of moveable louvers for the introduction of air into the room to be conditioned.  
 It can be installed directly onto the appliance by removing the flanges or on the wall.
- GAP Intake grid**  
 With fixed louvers inclined by 45°; can be installed directly onto the appliance by removing the flanges or on the wall.
- FPI G4 flange filters**
- PX Switch-over only control panel**
- WMT 05 Electro-mechanical thermostat**  
 For fan coils installed in 2 pipe systems The panel must be installed on the wall and protected electrically by an internal fuse.  
 Has the following functions: on/off switch; cursor for the selection of heating/cooling modes (manual season change); cursor for the selection of fan speed (high, medium and low); temperature selector switch (+5°C÷30°C)
- WMT10 Control panel**  
 For can coils with wall installation.  
 Control functioning of the fan coil depending on the mode set.  
 The panel must be mounted on the wall, it is used on 4 pipe and 2 pipe and 2 pipe with resistance systems, with the possibility of connecting two On - Off type valves for the cut-off of the coil supply water. The panel is protected electrically by an internal fuse.  
 The control has the following functions: cursor for the selection of the cooling or heating functioning mode; manual season change; manual selection of the fan speed selection of the desired environment temperature (+10°C÷30°C); 2 pipe systems management; 4 pipe systems management; 2 pipe systems management (cooling) + electrical resistance (heating); thermostat ventilation; continuous ventilation; continuous ventilation in cooling mode and thermostat ventilation in heating mode.

Accessories compatibility

	TA 09	TA 11	TA 15	TA 19	TA 24	TA 33	TA 40	TA 50
<b>M2S</b>	M2S1	M2S1	M2S2	M2S3	M2S4	M2S4	M2S5	M2S5
<b>M3S</b>	M3S1	M3S1	M3S2	M3S3	M3S4	M3S4	M3S5	M3S5
<b>FTF</b>	FTF1	FTF1	FTF2	FTF3	FTF4	FTF4	FTF5	FTF5
<b>B1R</b>	B1R1	B1R1	B1R2	B1R3	B1R4	B1R4	B1R5	B1R5
<b>B2R</b>	B2R1	B2R1	B2R2	B2R3	B2R4	B2R4	B2R5	B2R5
<b>PBE</b>	PBE1	PBE2	PBE3	PBE4	PBE5	PBE6	PBE7	PBE8
<b>SSL</b>	SSL1	SSL1	SSL2	SSL3	SSL4	SSL4	SSL5	SSL5
<b>S2Z</b>	S2Z1	S2Z1	S2Z2	S2Z3	S2Z4	S2Z4	S2Z5	S2Z5
<b>VRF</b>	VRF1	VRF2	VRF3	VRF4	VRF5	VRF6	VRF7	VRF8
<b>PMM</b>	PMM1	PMM1	PMM2	PMM3	PMM4	PMM4	PMM5	PMM5
<b>PMC</b>	PMC1	PMC1	PMC2	PMC3	PMC4	PMC4	PMC5	PMC5
<b>SAS</b>	SAS1	SAS1	SAS2	SAS3	SAS4	SAS4	SAS5	SAS5
<b>GMD</b>	GMD1	GMD1	GMD2	GMD3	GMD4	GMD4	GMD5	GMD5
<b>GAP</b>	GAP1	GAP1	GAP2	GAP3	GAP4	GAP4	GAP5	GAP5
<b>FPI</b>	FPI1	FPI1	FPI2	FPI3	FPI4	FPI4	FPI5	FPI5
<b>PX</b>	•	•	•	•	•	•(2)	•(2)	•(2)
<b>WMT 05</b>	•	•(1)	•(1)	•(1)	•(1)	•(2)	•(2)	•(2)
<b>WMT 10</b>	•	•(1)	•(1)	•(1)	•(1)	•(2)	•(2)	•(2)

(1) Envision the use of SIT and the replacement of the 2A fuse with one 4A fuse

(2) Envisions return relay, one per speed

## Technical data

Mod. TA		9	11	15	19	24	33	40	50	
Nominal air flow rate	m <sup>3</sup> /h	900	1100	1500	1900	2400	3300	4000	5000	
	l/s	250	306	417	528	667	917	1111	1389	
Useful static pressure (1)	Pa	110	277	249	223	165	215	220	163	
Cooling capacity with 4 row coil (2)	total	kW	4.7	5.7	8.7	12.4	17.3	21.7	27.2	31.8
	sensible	kW	3.5	4.2	6.2	8.3	11.2	14.3	18.0	21.3
Cooling capacity with 6 row coil (2)	total	kW	5.4	6.7	11.7	15.5	20.6	26.3	33.5	39.6
	sensible	kW	3.9	4.7	7.5	9.8	12.8	16.6	20.9	25.0
Cooling capacity with 4 row coil with direct exp.R-410A (3)	total	kW	6.6	7.3	11.0	14.2	19.2	23.0	30.5	34.5
	sensible	kW	4.2	4.7	7.0	9.1	12.1	14.8	19.4	22.3
Heating capacity with 4 row coil (4)	kW	14.2	16.6	23.9	30.8	40.6	52.2	65.8	78.3	
Heating capacity with 6 row coil (4)	kW	15.7	18.5	26.6	34.2	44.3	58.0	72.6	87.5	
1 row water coil heating capacity for 4 row pipes (8)	kW	5.2	5.7	9.2	11.4	15.9	18.3	25.2	27.7	
2 row water coil heating capacity for 4 row pipes (8)	KW	8.4	9.5	14.2	17.9	24.3	29.9	38.9	44.9	
Heating capacity with 4 row coil (5)	KW	5.5	6.4	9.3	12.1	16.0	20.6	25.9	30.8	
Heating capacity with 6 row coils (5)	KW	6.1	7.2	10.5	13.6	17.6	23.0	28.9	34.8	
1 row water coil heating capacity for 4 row pipes (5)	KW	2.2	2.4	4.0	4.9	6.9	7.9	10.9	12.0	
2 row water coil heating capacity for 4 row pipes (5)	KW	3.6	4.1	6.2	7.8	10.6	13.0	16.9	19.5	
Electric coil capacity	KW	4	6	8	10	12	16	20	24	
Number of electric coil stages	n°	2	2	2	2	2	2	2	2	
Electric coil power supply		400V-3-50Hz								
Fans	n°	1	2	2	1	1	2	2	2	
Motors	n°	1	2	2	1	1	2	2	2	
Fans total input power	W	357	713	713	886	874	1771	1771	2852	
Fans input current	A	1,6	3,1	3,1	3,9	3,8	7,7	7,7	12,4	
Fans power supply		230V-1-50Hz								
Poles	n°	2	2	2	4	4	4	4	4	
Flat filters capacity (6)		G4	G4	G4	G4	G4	G4	G4	G4	
Soft bag filters efficiency (6)		F6	F6	F6	F6	F6	F6	F6	F6	
Sound power level (7)	dB(A)	63	66	67	72	74	75	76	79	
<b>Connections</b>										
Coils collectors	Ø inc.	1"	1"	1"	1"	1"	1"	1"	1"	
Direct expansion coil pipes	IN	Ø mm.	16	16	16	16	16	22	22	
	OUT	Ø mm.	22	22	22	22	22	28	28	
Condensate Drain	Ø inc.	¾	¾	¾	¾	¾	¾	¾	¾	

- (1) At nominal capacity with 4 row coil
- (2) Entry air temperature 27°C d.b. 19°C w.b.; water temperature (Ent-Ex) 7°C - 12°C
- (3) Entry air temperature 27°C d.b. 19°C w.b.; medium evap. temperature 2°C
- (4) Entry air temperature 10°C; Water temperature (Ent-Ex) 70°C - 60°C
- (5) Entry air temperature 20°C; Water temperature (Ent-Ex) 45°C - 40°C
- (6) Inc with the EN 779 Standard
- (7) Sound power in compliance with UNIX EN ISO 9614-2 Standards
- (8) Entry air temperature 15°C; Water temperature (Sent-Ex) 70°C - 60°C

## Dimensional data (mm)

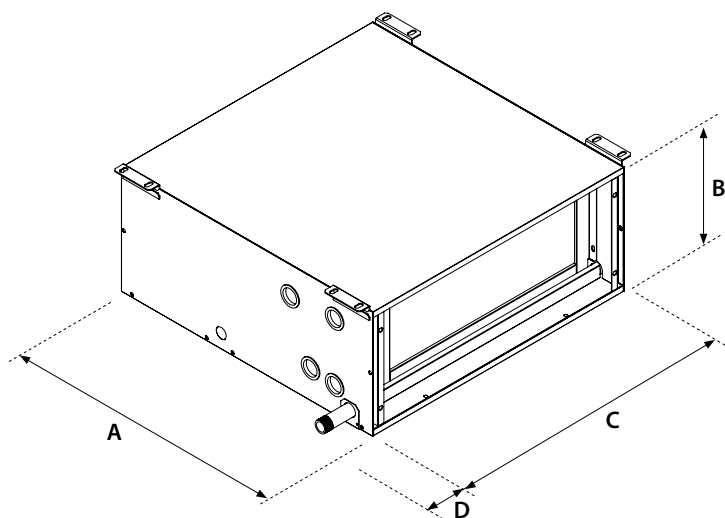

TA HORIZONTAL INSTALLATION AND WITH EXTRACTOR

Mod. TA		9	11	15	19	24	33	40	50
<b>HORIZONTAL CONFIGURATION DIMENSIONS AND "EXTRACTOR" CONFIGURATION</b>									
Height (B)	mm	300	300	300	390	390	390	390	390
Width (C)	mm	700	700	1050	1050	1475	1475	2100	2100
Length (A)	mm	700	700	700	850	850	850	1000	1000
Connections projection (D)	mm	82	82	82	82	82	82	82	82
Number of fans	n°	1	2	2	1	1	2	2	2

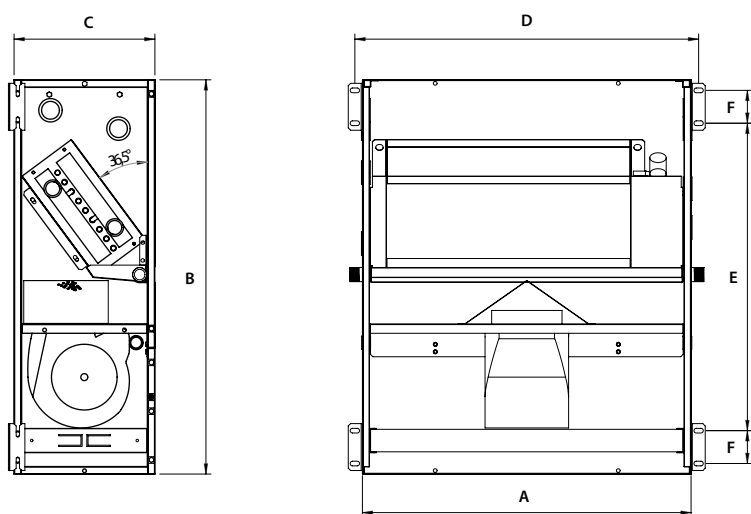

TA VERTICAL INSTALLATION

Mod. TA		9	11	15	19	24	33	40	50
<b>VERTICAL CONFIGURATION DIMENSIONS</b>									
Height (B)	mm	840	840	840	1090	1090	1090	1090	1090
Width (C)	mm	300	300	300	390	390	390	390	390
Length (A)	mm	700	700	1050	1050	1475	1475	2099	2099
Fixing points (D)	mm	732	732	1082	1082	1507	1507	2131	2131
(E)	mm	655	655	655	905	905	905	905	905
(F)	mm	70	70	70	70	70	70	70	70
Number of fans	n°	1	2	2	1	1	2	2	2

<b>UNIT NET WEIGHTS</b>		9	11	15	19	24	33	40	50
4 row coil	mm	28	33	45	60	78	86	135	140
6 row coil	kg	30	35	47	62	81	89	139	144
Extractor	kg								

Aermec reserves the right to make all modification deemed necessary for improving the product at any time with any modification of technical data.

**Aermec S.p.A.**  
Via Roma, 996 - 37040 Bevilacqua (VR) - Italy  
Tel. 0442633111 - Telefax 044293577  
www.aermec.com